



No. 274

Date 12/16/94

Another addition to the expanding line of Webb products.

NEW PRODUCT BULLETIN

PART NUMBER: 2431

HUB

DESCRIPTION: 10 Stud 13.189 (335MM) BC
For Outboard Drum (Serrated Stud)

AVAILABLE
NOW

ESTIMATED WEIGHT: 62 Lbs.
(Hub Only)

APPLICATION INFORMATION
TRAILER AXLE

AXLE APPLICATION

WEBB AXLE GROUP #7
OUTER BEARING CUP 742
 CONE 740
INNER BEARING CUP 752
 CONE 759

AXLE MODELS
DANA SPICER K-30
INGERSOLL A-26
STANDARD FORGE A-25, A-26

PRODUCT INFORMATION

NOTE: REPLACES WEBB 1432 HUB

"B"	"C"	"D"	"E"			"F"	"G"	"H"	"I"	"J"	"K"	"L"	Grease Hub Cap Kit
Distance Between Cups	Cup To Mfg. Face	Cup to End of Drum	Part No.	Brake Drum Order Code Standard	Order Code Balanced	Brake Size Dia.	Brake Width	Drum Overall Depth	Drum Pilot Dia.	Bolt Circle	Drum Bolt Qty. Dia.	Hub Cap Hole Pattern	
4.06	1.68 1.68	8.91 10.69	66250 66258	FJ FK	EJ EU	16.50 16.50	7.00 8.62	10.59 12.37	11.25 11.25	13.189 (335MM)	10 FOR STUD INFO. SEE REVERSE SIDE	6 Holes 0.31Ø 6.75 Dia. BC	Not Avail.

SEE REVERSE SIDE FOR WHEEL FASTENER INFORMATION

WHEEL FASTENER INFORMATION For Use with Pilot Mounted Disc Wheels (M22 x 1.5 Stud)

1 Disc Wheel	2 Tire App.	3 Drum Make	4 Stud (RH)	5 Color	6 Flange Nut	7 Stud Stand Out	8 Order Code for Flange Nuts	
							With	Less
Steel	Dual	Cast	101162	Black	179933	2.47	4	3
Aluminum	Dual	Cast	101160	Black	179933	3.32	6	5
1-Steel/1-Alum	Dual	Cast	101160	Black	179933	3.32	6	5
Steel	Single	Cast	101164	Black	179933	2.03	2	1
Aluminum	Single	Cast	101162	Black	179933	2.47	4	3

WHEEL FASTENER INFORMATION British Standard (7/8-11 BSF Studs)

1 Disc Wheel	2 Tire App.	3 Drum Make	4 Stud (RH)	5 Color	6 Stud (LH)	7 Color	8		9 Stud Stand Out	10 Wheel Nut-Washer Order Code	
							RH BSF Nut	LH BSF Nut		With	Less
Steel	Dual	Cast	184782	Silver	184783	Yellow	74622	74623	2.28	A	M
Use 289 Centering Washer											

WHEEL FASTENER INFORMATION (For European (DIN) Mounting Using M22 x 1.5 Stud)

1 Disc Wheel	2 Tire App.	3 Drum Type	4 Stud	5 Color	6 Centering Washer	7 Lock Washer	8 Wheelnut	9 Stud Stand Out	10 Wheel Nut Order Code	
									With	Less
Steel	Dual	Cast	101181	Black	290	170	Not Avail.	2.47	84	83

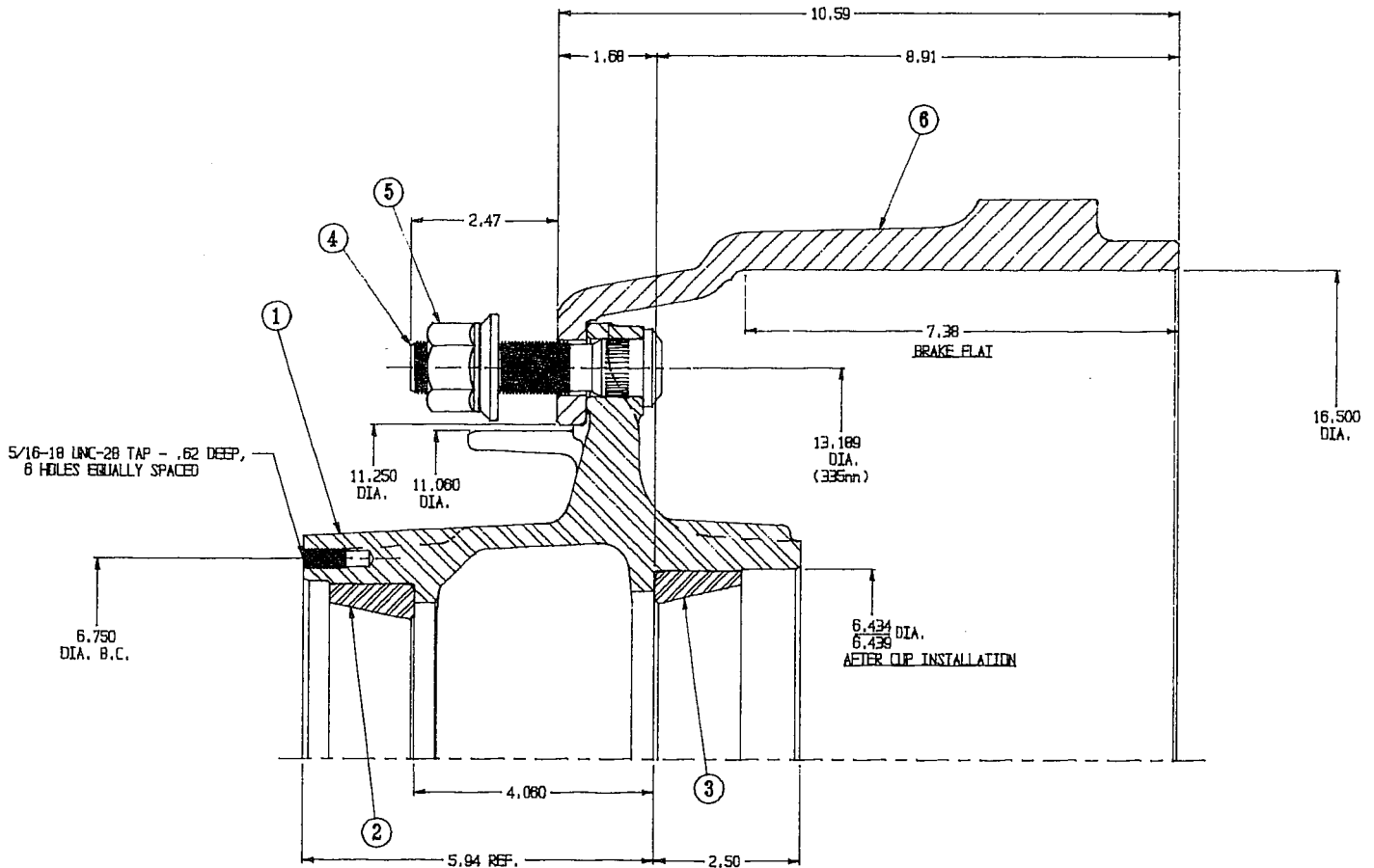

LIST OF COMPONENTS			
ITEM	PART #	DESCRIPTION	QTY.
1	2431F	HUB - 10 STUD	1
2	742	OUTER BEARING CLIP	1
3	752	INNER BEARING CLIP	1
4	101162	M22 SERRATED STUD, 3.94 LONG	10
5	179933	M22 FLANGE NUT	10
6	66250F	BRAKE DRUM, 16.50 x 7.00	1

VEBB ORDER CODE: 24311F-B (ASSEMBLY LESS FLANGE NUTS)
24311F-J (ASSEMBLY WITH FLANGE NUTS)

DYNAMIC LOAD CAPACITY : 15,000 LBS. PER HUB